

Schemes for the observation of photon correlation functions in circuit QED with linear detectors

Marcus P. da Silva,¹ Deniz Bozyigit,² Andreas Wallraff,² and Alexandre Blais¹

¹*Département de Physique, Université de Sherbrooke, Sherbrooke, Québec, Canada, J1K 2R1*

²*Department of Physics, ETH Zürich, CH-8093, Zürich, Switzerland.*

(Dated: April 23, 2010)

Correlations are important tools in the characterization of quantum fields. They can be used to describe statistical properties of the fields, such as bunching and anti-bunching, as well as to perform field state tomography. Here we analyse experiments by Bozyigit *et al.* [1] where correlation functions can be observed using the measurement records of linear detectors (*i.e.* quadrature measurements), instead of relying on intensity or number detectors. We also describe how large amplitude noise introduced by these detectors can be quantified and subtracted from the data. This enables, in particular, the observation of first- and second-order coherence functions of microwave photon fields generated using circuit quantum-electrodynamics and propagating in superconducting transmission lines under the condition that noise is sufficiently low.

I. INTRODUCTION

Correlations are powerful tools in the characterization of classical and quantum fields [2, 3]. Particular examples of useful correlations are the coherence functions of a field, as described by Glauber [4–6]. These functions can be used to quantify the ability of a field to interfere with itself, as well as to demonstrate features of quantum fields which cannot be reproduced in a classical system. The most famous of these quantum phenomena is known as *anti-bunching* [7, 8], and it is frequently used to characterize single-photon sources in the optical regime [9–13]. Over the recent years Josephson-junction based superconducting circuits, resonators and transmission lines have emerged as a platform for performing quantum optics experiments in the microwave regime [14–24]. While in the optical regime coherence functions are usually measured using an interferometer where photon number detectors are used, in the microwave regime, linear detectors (*i.e.* field quadrature measurements) are more common. This raises the question of how to measure field correlations using linear detectors. This paper answers this question and describes the theory behind the recent experiments performed by Bozyigit *et al.* [1], where correlations of a propagating microwave field are measured using only linear detectors, instead of intensity detectors. While the discussion here focuses on the measurement of first- and second-order coherence functions of microwave fields, the analysis can be applied to any correlation of field operators. We note that the measurement of correlation functions of propagating microwave fields using non-linear (*i.e.* square-law) detectors was theoretically studied in Ref. [25] under the assumption of negligible correlation in the noise added by the detection chain. In practice, these correlations turn out to be important and are discussed here. Recent work by Menzel *et al.* [26] and Mariantoni *et al.* [27] is in a similar direction to the work presented here.

The paper is organized as follows. Section II gives a brief review of coherence functions and how they are

measured with non-linear detectors. Section III describes how field correlations, and in particular coherence functions, can be measured using linear detectors. Section IV describes the effects of noise in the experiments, and finally Section V describes how the experimental setup can be simplified in circuit QED experiments.

II. COHERENCE FUNCTIONS

The meaning of *coherence* of a field in a single frequency mode, with corresponding annihilation operator \hat{a} , can be understood by considering interference experiments which use the field leaking out of this mode. Using a double slit, the field can be made to travel two pathways of different lengths which terminate at a single point-like photon detector, as depicted in Fig. 1(a). The combined field that impinges on the detector is made up of fields originally emitted at times t and $t + \tau$ (which depend on the lengths of the paths), so that the observed field intensity at the detector is the sum of the intensities of the two fields plus an interference term which depends on $\langle \hat{a}^\dagger(t)\hat{a}(t + \tau) \rangle$ [2]. Interference effects can only be observed if this correlation is non-zero. It is therefore natural to define

$$G^{(1)}(t, t + \tau) = \langle \hat{a}^\dagger(t)\hat{a}(t + \tau) \rangle, \quad (1)$$

which is called the *first-order coherence function* [4], as a measure of the emitted field's potential to interfere with itself – in other words, a measure of the coherence of the field. One may also consider

$$G^{(1)}(\tau) = \int_{\mathcal{I}} dt G^{(1)}(t, t + \tau), \quad (2)$$

for some time interval \mathcal{I} in order to obtain an expression that depends only on the time difference between the two paths. If $G^{(1)}(\tau) = 0$, no interference effects can be observed for a path difference of $c\tau$, where c is the speed of light.

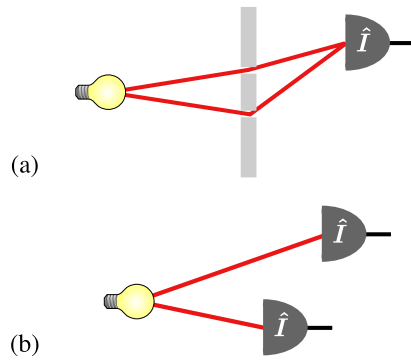

FIG. 1: (Color online) Experimental setups illustrating different degrees of optical coherence with intensity detectors. The red lines represent quantum fields, and the black lines represent measurement records.

The measure of coherence that is most often used to distinguish classical fields from quantum fields is the *second-order coherence function* given by

$$G^{(2)}(t, t + \tau) = \langle \hat{a}^\dagger(t) \hat{a}^\dagger(t + \tau) \hat{a}(t + \tau) \hat{a}(t) \rangle, \quad (3)$$

or by the integrated version

$$G^{(2)}(\tau) = \int_{\mathcal{I}} dt G^{(2)}(t, t + \tau). \quad (4)$$

The canonical experiment which gives the physical interpretation of $G^{(2)}$ is one with a single light source and two point-like detectors, such that the field takes a time t and $t + \tau$ respectively to reach each detector, as depicted in Fig. 1(b). In that case the correlation between the detected intensities is given by $G^{(2)}(t, t + \tau)$.

For classical fields, where the field operator in the expressions above are replaced by c -numbers, one finds that $|G^{(2)}(0)| \geq |G^{(2)}(\tau)|$, while there are quantum states of the field that yield $|G^{(2)}(0)| < |G^{(2)}(\tau)|$ for $\tau \neq 0$, a phenomenon known as *anti-bunching* [7, 8]. The canonical examples of anti-bunched field states are single photon states and squeezed states. In the case of pulsed experiments – where the light field state is prepared with a repetition period of t_p – one writes instead that classical fields obey $|G^{(2)}(0)| \geq |G^{(2)}(kt_p)|$, and that some quantum states of the field yield $|G^{(2)}(0)| < |G^{(2)}(kt_p)|$ for $k \neq 0$. Only pulsed experiments will be considered in the remainder of this paper, the generalization to continuous experiments being straightforward.

A. Standard experimental setups

As illustrated in Fig. 2, we consider experiments where the source is a single mode of a cavity which is coupled to a transmission line via a leaky mirror, a situation typical of cavity QED [28–30]. In circuit QED for example, arbitrary superpositions of a single photon and vacuum

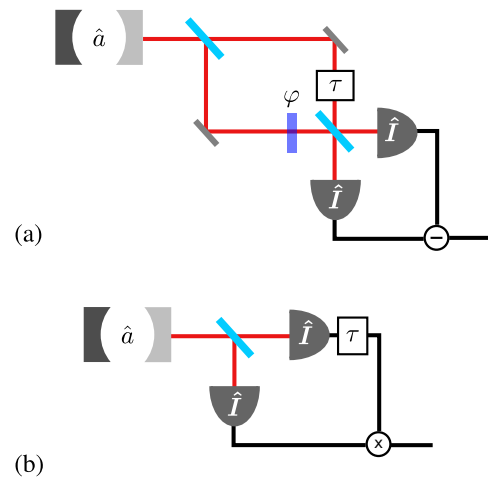

FIG. 2: (Color online) Standard experiments for the observation of $G^{(1)}$ and $G^{(2)}$ using intensity detectors: (a) a Mach-Zender interferometer with a variable delay τ and a variable phase shift φ , and (b) a Hanbury Brown and Twiss (HBT) interferometer with a variable delay τ . The light-blue components are balanced beam-splitters. The cavity is taken to be one-sided, with one mirror being perfectly reflecting.

can be prepared in the dispersive regime via the Purcell effect [17] or by strong coupling to a qubit brought into resonance with the cavity [1], although details of the state preparation are not important for the remainder of the discussion. The harmonic field in the cavity is associated with an annihilation operators \hat{a} with the usual same-time commutation relation $[\hat{a}, \hat{a}^\dagger] = \mathbb{1}$. Using input-output theory [3, 31–33], one can show that \hat{a} is related to the modes of the transmission line via

$$\hat{b}_{\text{out}}(t) = \sqrt{\kappa_b} \hat{a}(t) - \hat{b}_{\text{in}}(t), \quad (5)$$

where κ_b is the rate at which photons leak out of \hat{a} , and the input and output fields are given by

$$\hat{b}_{\text{in}}(t) = \frac{1}{\sqrt{2\pi}} \int_{-\infty}^{+\infty} d\omega e^{-i\omega(t-t_0)} b(t_0, \omega) \quad (6)$$

$$\hat{b}_{\text{out}}(t) = \frac{1}{\sqrt{2\pi}} \int_{-\infty}^{+\infty} d\omega e^{-i\omega(t-t_1)} b(t_1, \omega) \quad (7)$$

for transmission line modes $b(t, \omega)$ at times $t_0 < t < t_1$, and correspond to fields propagating towards or away from the cavity. The commutation relations of the input and output fields are given by

$$[\hat{b}_{\text{in}}(t), \hat{b}_{\text{in}}^\dagger(t + \tau)] = [\hat{b}_{\text{out}}(t), \hat{b}_{\text{out}}^\dagger(t + \tau)] = \delta(\tau). \quad (8)$$

These definitions lead to an equation of motion for \hat{a} in the interaction frame to be given, for a one-sided cavity, by

$$\dot{\hat{a}}(t) = -\frac{\kappa_b}{2} \hat{a}(t) + \sqrt{\kappa_b} \hat{b}_{\text{in}}(t). \quad (9)$$

From Eq. (5) it is clear that the correlations of \hat{b}_{out} are proportional to the correlations of \hat{a} . The remainder of the discussion will focus on the observation of the coherence functions of the output field \hat{b}_{out} only, as they can be taken to be equivalent to the correlation functions of \hat{a} . The “out” subscript will also be dropped when it is clear from the context.

The state of the cavity field is taken to be prepared at times $t = kt_p$ for integer k and repetition period t_p , and allowed to decay via the leaky mirror as described above. The repetition period is chosen to obey $t_p \gg 2\pi/\kappa_b$ so that the cavity can be taken to be in equilibrium at the time of the next preparation of the cavity field.

When working with photons in the optical frequencies, $G^{(1)}$ is usually observed using a Mach-Zender interferometer with a variable delay of τ in one of the branches [34], as depicted in Fig. 2(a). The difference between the intensities in the photo-current detectors can yield the real or the imaginary part of $G^{(1)}$, depending on the phase shift φ in the lower branch. The standard approach to the observation of the $G^{(2)}$ is to use a Hanbury Brown and Twiss (HBT) interferometer [34], which is illustrated in Fig. 2(b). In order to observe $G^{(2)}$, one simply measures the correlations between the photo-currents of the two detectors.

Both these setups rely on field intensity detectors, which give information about the number of photons, and thus can be modeled by non-linear quantum optical interactions¹. Low-noise intensity detectors for optical fields are common, and although non-linear detectors have been demonstrated in the microwave regime [17, 35], the main motivation for this paper is to illustrate how the coherence functions of microwave fields in circuit QED may be measured through the use of linear detectors only.

III. LINEAR DETECTORS

Field quadrature measurements of microwave signals is a standard technique [36] which has been applied very successfully to quantum electrical circuits in the recent years [14, 15, 37, 38]. Since field quadrature operators are fundamentally different from number operators, different experimental setups are required in order to measure the coherence functions $G^{(1)}$ and $G^{(2)}$. Grosse *et al.* [39] have demonstrated how a HBT interferometers can be modified to measure $G^{(2)}$ using field quadratures instead of intensity measurements. Here we analyse similar experiments [1], and consider generalizations and simplifications which exploit features of circuit QED, while at the same time considering the large added noise due to the HEMT amplifiers currently required for measurement in

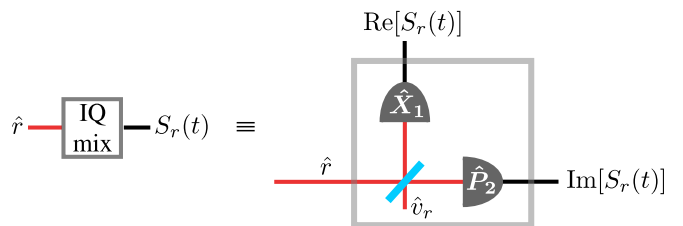

FIG. 3: Optical analog of an IQ-mixer as an 8-port homodyne detector. The field \hat{r} is fed into a balanced beam splitter along with vacuum \hat{v}_r . The \hat{X} quadrature of one of the beam splitter outputs is measured while the \hat{P} quadrature of the other output is measured. The classical outcomes are the real and imaginary parts of the complex envelope $S_r(t)$.

this architecture.

The details of the implementation of quadrature operator measurements in the microwave regime are different from the standard optical implementation. In particular, homodyne detection in the microwave regime is performed via mixing instead of beam splitting [36]. For simplicity, we will however consider the optical analogues of the devices we discuss. Common non-idealities in the microwave regime, such as weak thermal states instead of vacuum inputs, can be treated straightforwardly by considering different input states, and thus do not change the analysis significantly.

The measurement of both quadratures of a propagating field, known in optics as 8-port homodyne [40] or heterodyne detection depending on the choice of local oscillator frequency, is performed by an *IQ mixer* in the microwave regime [36]. The symbol for the IQ mixer, and its description in terms of its optical analogue are depicted in Fig. 3. The input is any propagating quantum field with annihilation operator \hat{r} , which may stand for any propagating field considered in this paper. The outputs are quadrature measurements of the superpositions of the \hat{r} field with a mode \hat{v}_r in the vacuum state, where $[\hat{r}, \hat{v}_r^\dagger] = 0$. These outputs are labeled X_1 and P_2 to emphasize that the measurements are made on different commuting modes, and correspond to the in-phase component and the quadrature component of the measurement respectively.

Finally, it is important to note that, for most circuit QED experiments, only averages of these quadratures over many realizations of the experiment are measured. Here, we are interested in experiments where the full time records of these quadratures are recorded, for each realizations of the experiments [1]. Based on these full records, any averages or correlation functions can be reconstructed, as is discussed in the next sections.

¹ Linearity in this sense refers to the representability of the Heisenberg picture evolution by a linear transformation of creation and annihilation operators for all times.

A. Complex envelope

Given the two classical outputs $X_1(t)$ and $P_2(t)$, it is useful to define the complex envelope $S_r(t)$ of \hat{r} as

$$S_r(t) = X_1(t) + iP_2(t), \quad (10)$$

which is a random c-number due to the dependence on the measurement records of the quadratures. Noting that

$$\langle X_1(t) \rangle = \left\langle \frac{\hat{r}_1 + \hat{r}_1^\dagger}{\sqrt{2}} \right\rangle = \langle \hat{X}_r(t) \rangle + \langle \hat{X}_v(t) \rangle \quad (11)$$

$$\langle P_2(t) \rangle = -i \left\langle \frac{\hat{r}_2 - \hat{r}_2^\dagger}{\sqrt{2}} \right\rangle = \langle \hat{P}_r(t) \rangle - \langle \hat{P}_v(t) \rangle, \quad (12)$$

one may write that $\langle S_r(t) \rangle = \langle \hat{S}_r(t) \rangle$ where the complex envelope operator \hat{S}_r is defined by

$$\hat{S}_r(t) \equiv \hat{r}(t) + \hat{v}_r^\dagger(t) = \hat{X}_1(t) + i\hat{P}_2(t). \quad (13)$$

In order to simplify the remainder of the calculations, it is convenient to define \hat{S}_r in this manner instead of using the quadrature operators explicitly.

Given that the mode \hat{v}_r is prepared in the vacuum state, the expression for the expectation values take simple forms. The presence of the vacuum mode \hat{v}_r is indeed important as it leads to the commutation relation

$$[\hat{S}_r(t), \hat{S}_r^\dagger(t')] = 0, \quad (14)$$

implying that \hat{S}_r is normal and therefore diagonalizable. Since \hat{S}_r is described by the sum of the commuting operators \hat{X}_1 and \hat{P}_2 , its eigenvalues are given by the sum of the eigenvalues of these operators for any fixed eigenvector. This corresponds to the measurement record S_r of \hat{S}_r being simply the sum of the measurement records X_1 and P_2 , as claimed earlier. Note that this does *not* imply that both quadratures of \hat{r} can be measured simultaneously without back-action.

Since \hat{S}_r and \hat{S}_r^\dagger commute at all times, arbitrary correlations of these operators, like the correlations of their measurement records, do not depend on operator ordering. Therefore,

$$\langle (S_r^*)^m S_r^n \rangle = \langle (\hat{S}_r^\dagger)^m \hat{S}_r^n \rangle = \langle (\hat{r}^\dagger + \hat{v}_r)^m (\hat{r} + \hat{v}_r^\dagger)^n \rangle, \quad (15)$$

independently of the ordering of the terms. However, in order to reduce these expressions to a correlation function of \hat{r} alone, one must rewrite the expression such that the \hat{v}_r modes are in normal ordering in order to immediately evaluate the expectation values, leading to

$$\langle (S_r^*)^m S_r^n \rangle = \langle (\hat{S}_r^\dagger)^m \hat{S}_r^n \rangle = \langle \hat{r}^n (\hat{r}^\dagger)^m \rangle, \quad (16)$$

or in other words, correlations of the complex envelope of a field correspond to anti-normally ordered correlations of the field operator, under the assumption that the \hat{v}_r mode is prepared in the vacuum. In this case the measurement

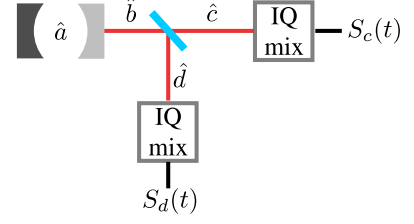

FIG. 4: Hanbury Brown and Twiss interferometer with complex envelope measurement used to measure the first-order coherence function $G^{(1)}$. The output of the cavity field is separated by an on-chip beam splitter and the resulting fields measured by an IQ-mixer.

of \hat{S}_r is described by the Husimi-Kano Q function which is known to give access to anti-normally ordered same-time correlations [40–42]. Similar results hold for multi-time correlations.

It is important to note that, while with this approach arbitrary correlations can be evaluated, the number of statistical samples needed to obtain a desired precision in the estimate grows as the noise power raised to the desired correlation order (see Appendix A for details). In practice, this limits the order of the correlations measured with current amplifier noise levels due to the large number of repetitions of the experiment needed to obtain reasonable error bars. Use of quantum limited amplifiers would greatly improve the situation [21, 22, 43].

B. $G^{(1)}$ observation

As depicted in Fig. 4, with IQ-mixers, the first order correlation function $G^{(1)}$ can be measured from the outputs of a HBT interferometer. Because of the unitarity of the beam splitter and the presence of a vacuum port, the complex envelope operators of the outputs labeled \hat{c} and \hat{d} commute.

The auto-correlation of one of the complex envelopes, say $S_c(t)$, is given by

$$\Gamma_\alpha^{(1)}(t, t+\tau) = \langle \hat{S}_c^\dagger(t) \hat{S}_c(t+\tau) \rangle = \delta(\tau) + \frac{1}{2} \langle \hat{b}^\dagger(t) \hat{b}(t+\tau) \rangle, \quad (17)$$

while the cross-correlation between the complex envelopes is by

$$\Gamma_\beta^{(1)}(t, t+\tau) = \langle \hat{S}_c^\dagger(t) \hat{S}_d(t+\tau) \rangle = \frac{1}{2} \langle \hat{b}^\dagger(t) \hat{b}(t+\tau) \rangle, \quad (18)$$

where we have used the fact that the expectation values of all the vacuum modes are zero. Thus the first-order coherence function $G^{(1)}$ of the \hat{b} field is immediately accessible from cross-correlations of the complex envelopes in a modified HBT interferometer via

$$\begin{aligned} G^{(1)}(t, t+\tau) &= 2\Gamma_\alpha^{(1)}(t, t+\tau) - 2\delta(\tau), \\ &= 2\Gamma_\beta^{(1)}(t, t+\tau), \end{aligned} \quad (19)$$

up to non-idealities, such as amplifier noise, which will be treated later.

Although the divergence of the δ functions may appear problematic, in reality due to the finite bandwidth of the experiments these delta functions are replaced by smooth bounded functions, while the coherence functions are distorted by a convolution kernel which preserves the relative heights of the peaks in the experiment. This results in the filtered correlation functions

$$\begin{aligned}\Gamma_{\alpha,\text{fil}}^{(1)}(\tau) &= \frac{1}{2}G_{\text{fil}}^{(1)}(\tau) + f_{\text{eff}}(\tau), \\ \Gamma_{\beta,\text{fil}}^{(1)}(\tau) &= \frac{1}{2}G_{\text{fil}}^{(1)}(\tau).\end{aligned}\quad (20)$$

where $G_{\text{fil}}^{(1)}(\tau) = G^{(1)}(\tau) * f_{\text{eff}}(\tau)$ and f_{eff} is a function describing the effective action of the filter (see Appendix B for details).

C. $G^{(2)}$ observation

The expressions needed to measure the second-order coherence function from the complex envelopes can be constructed by inspection from Eq. (13). Depending on which factors are taken to be complex conjugates or to be displaced in time by τ , different correlations can be used to extract information about $G^{(2)}$. One such choice is

$$\begin{aligned}\Gamma_{\alpha}^{(2)}(t, t + \tau) &= \langle \hat{S}_c^\dagger(t) \hat{S}_d^\dagger(t + \tau) \hat{S}_d(t + \tau) \hat{S}_c(t) \rangle \\ &= \delta^2(0) + \frac{1}{2} \langle \hat{b}^\dagger(t) \hat{b}(t) \rangle \delta(0) + \frac{1}{2} \langle \hat{b}^\dagger(t + \tau) \hat{b}(t + \tau) \rangle \delta(0) \\ &\quad + \frac{1}{4} \langle \hat{b}^\dagger(t) \hat{b}^\dagger(t + \tau) \hat{b}(t + \tau) \hat{b}(t) \rangle,\end{aligned}\quad (21)$$

so that $G^{(2)}$ can be obtained immediately via

$$\begin{aligned}G^{(2)}(t, t + \tau) &= 4\Gamma_{\alpha}^{(2)}(t, t + \tau) - 2G^{(1)}(t, t)\delta(0) \\ &\quad - 2G^{(1)}(t + \tau, t + \tau)\delta(0) - 4\delta^2(0).\end{aligned}\quad (22)$$

Another choice that leads more directly to $G^{(2)}$ is

$$\begin{aligned}\Gamma_{\beta}^{(2)}(t, t + \tau) &= \langle \hat{S}_c^\dagger(t) \hat{S}_c^\dagger(t + \tau) \hat{S}_d(t + \tau) \hat{S}_d(t) \rangle, \\ &= \frac{1}{4} \langle \hat{b}^\dagger(t) \hat{b}^\dagger(t + \tau) \hat{b}(t + \tau) \hat{b}(t) \rangle,\end{aligned}\quad (23)$$

so that

$$G^{(2)}(t, t + \tau) = 4\Gamma_{\beta}^{(2)}(t, t + \tau).\quad (24)$$

Once again, the divergence of the δ functions is taken care of by filtering in a realistic experiment. The main distinction between these two approaches of measuring the second-order coherence functions is how they are affected by noise in the experiment, as is discussed in the next section.

IV. REJECTION AND SUBTRACTION OF NOISE

The amplitude of microwave signals in a superconducting quantum circuit is small enough that amplifiers are essential for their observation, and so in a realistic experiment, the field is amplified *before* mixing. Using the Haus-Caves description of a quantum amplifier [33, 43, 44], an input operator \hat{c} and an output operator \hat{c}_{amp} for a phase-preserving amplifier with gain g_c are related by

$$\hat{c}_{\text{amp}} = \sqrt{g_c} \hat{c} + \sqrt{g_c - 1} \hat{h}_c^\dagger, \quad (25)$$

where \hat{h}_c is an added noise mode.

It is clear that if $g_c > 1$ there will be added noise due to amplification, even at zero temperature. However, for thermal white Gaussian noise, one finds that all odd order moments vanish. As a result, the first moments of quadrature fields are not affected by this amplifier noise, just as they are not affected by vacuum noise. The contributions from other moments may be non-zero, however, and must be accounted for. For simplicity, we only consider the case of Gaussian white noise here, but similar results follow straightforwardly for general noise as long as the noise is independent of the inputs. Since the noise moments can be extracted from experimental data, the assumption of Gaussian noise is not essential.

The noise modes from different amplifiers are taken to commute, but in general they may be correlated. While the noise is normally taken to come from the amplification [33, 43, 44], formally one may also take \hat{h}_c to include thermal noise from other sources, such as the vacuum ports of the IQ-mixer and of the beam-splitter, with only minor modifications. Here \hat{h}_c is taken to have a commutator $[\hat{h}_c(t), \hat{h}_c^\dagger(t + \tau)] = \delta(\tau)$ in order to preserve the bosonic commutation relations of the amplified signals \hat{c}_{amp} , and auto-correlation $\langle \hat{h}_c^\dagger(t) \hat{h}_c(t + \tau) \rangle = \bar{N}_c \delta(\tau)$. The noise sources are assumed to be independent of the inputs, so that $[\hat{c}, \hat{h}_c] = [\hat{c}, \hat{h}_c^\dagger] = 0$, and $\langle \hat{c} \hat{h}_c \rangle = \langle \hat{c} \hat{h}_c^\dagger \rangle = 0$. The correlations between \hat{h}_c and the noise mode \hat{h}_d from the other amplifier in the experiments described here is taken to be $\langle \hat{h}_c(t) \hat{h}_d^\dagger(t + \tau) \rangle = \bar{N}_{cd} \delta(\tau)$ while $\langle \hat{h}_c(t) \hat{h}_d(t + \tau) \rangle = 0$.

Using this noise model, one can calculate the different correlations $\Gamma_{\alpha,\beta}^{(1)}$ using the amplified modes, resulting in

$$\begin{aligned}\Gamma_{\alpha,\text{amp}}^{(1)}(t, t + \tau) &= \frac{g_c}{2} G^{(1)}(t, t + \tau) + (\bar{N}_c + g_c) \delta(\tau), \\ \Gamma_{\beta,\text{amp}}^{(1)}(t, t + \tau) &= \frac{\sqrt{g_c g_d}}{2} G^{(1)}(t, t + \tau) + \bar{N}_{cd} \delta(\tau),\end{aligned}\quad (26)$$

in the unfiltered case.

Since the thermal noise in the amplifiers is independent of the inputs, a steady-state experiment with the input mode \hat{b} in the vacuum state can be used to estimate the noise strengths and subtract the corresponding

terms from $\Gamma_{\alpha,\beta,\text{amp}}^{(1)}$ to obtain an estimate of $G^{(1)}$. When the noise cross-correlation \bar{N}_{cd} is expected to be zero or negligible compared to the noise auto-correlations \bar{N}_c and \bar{N}_d , the approach to the estimation of $G^{(1)}$ based on

$\Gamma_{\beta,\text{amp}}^{(1)}$ provides *noise rejection* without additional post-processing.

The second-order coherence function for the amplified fields has similar properties. One finds

$$\begin{aligned} \Gamma_{\alpha,\text{amp}}^{(2)}(t, t + \tau) &= \frac{g_c g_d}{4} G^{(2)}(t, t + \tau) + \frac{g_c}{2} \delta(0) [g_d + \bar{N}_d] G^{(1)}(t, t) + \frac{g_d}{2} \delta(0) [g_c + \bar{N}_c] G^{(1)}(t + \tau, t + \tau) \\ &+ \frac{\sqrt{g_c g_d}}{2} \bar{N}_{cd} \delta(\tau) [G^{(1)}(t + \tau, t) + G^{(1)}(t, t + \tau)] + [g_c \bar{N}_d + g_c g_d + g_d \bar{N}_c] \delta^2(0) + \langle \hat{h}_d^\dagger(t + \tau) \hat{h}_d^\dagger(t) \hat{h}_c(t) \hat{h}_c(t + \tau) \rangle, \end{aligned} \quad (27)$$

while

$$\begin{aligned} \Gamma_{\beta,\text{amp}}^{(2)}(t, t + \tau) &= \frac{g_c g_d}{4} G^{(2)}(t, t + \tau) + \langle \hat{h}_d^\dagger(t + \tau) \hat{h}_d^\dagger(t) \hat{h}_c(t) \hat{h}_c(t + \tau) \rangle \\ &+ \frac{\sqrt{g_c g_d}}{2} \bar{N}_{cd} \left[\delta(\tau) G^{(1)}(t + \tau, t) + \delta(0) G^{(1)}(t + \tau, t + \tau) + \delta(0) G^{(1)}(t, t) + \delta(\tau) G^{(1)}(t, t + \tau) \right], \end{aligned} \quad (28)$$

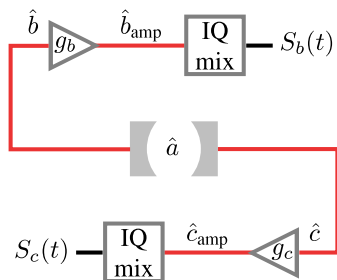

FIG. 5: The setup for the observation of coherence functions using a two-sided cavity.

where all odd moments of the noise modes were taken to be zero (if such an assumption cannot be made, similar expressions involving the odd moments are easily derived but are omitted here for brevity). The recovery of the second-order coherence function from noisy signals is clearly more involved, but requires only the estimation of first-order coherence functions, as well as two and four-point noise correlations in an experiment where the input mode \hat{b} is prepared in the vacuum. Since the filters are taken to be linear and time-invariant, $G_{\text{fil}}^{(2)}$ is a scaled and distorted version of $G^{(2)}$, preserving the relative heights of the peaks, so that the non-classical properties of the field can still be verified. Once again we see that $\Gamma_{\beta,\text{amp}}^{(2)}$ provides a more direct estimation of $G^{(2)}$ by rejecting contributions from uncorrelated noise up to four-point

noise correlations.

V. TWO-SIDED CAVITIES

Strictly speaking, the beam splitter is not necessary for the observation of the coherence functions described above. If one considers a two-sided cavity, illustrated in Fig. 5, the correlations between the cavity outputs behave in a manner similar to the outputs of the beam splitter in the HBT interferometers. In particular, using causality as well as the boundary conditions of the input and output fields of the two-sided cavity, Appendix C shows that

$$[\hat{b}_{\text{out}}(t), \hat{c}_{\text{out}}^\dagger(t')] = 0, \quad (29)$$

where \hat{c}_{out} is defined in a manner analogous to \hat{b}_{out} , with a mirror leakage rate κ_c , and an amplifier with gain g_c being applied before mixing and measurement. It is thus possible to measure the complex envelopes of the two cavity outputs and calculate the correlations in the same manner as in the modified HBT setup without the need for an additional beam splitter. This can lead to simpler and smaller experimental setups, as beam splitters in the microwave regime can occupy a significant area in coplanar devices.

Calculating the correlations using the two cavity outputs \hat{b}_{out} and \hat{c}_{out} one finds

$$\Gamma_{\alpha,\text{amp}}^{(1)}(t, t + \tau) = \kappa_c g_c G^{(1)}(t, t + \tau) + (\bar{N}_c + g_c) \delta(\tau), \quad (30)$$

$$\Gamma_{\beta,\text{amp}}^{(1)}(t, t + \tau) = \sqrt{\kappa_b \kappa_c} \sqrt{g_c g_d} G^{(1)}(t, t + \tau) + \bar{N}_{bc} \delta(\tau), \quad (31)$$

$$\begin{aligned} \Gamma_{\alpha,\text{amp}}^{(2)}(t, t + \tau) &= g_b g_c \kappa_b \kappa_c G^{(2)}(t, t + \tau) + [\bar{N}_b + g_b] \delta(0) g_c \kappa_c G^{(1)}(t, t) + [g_c + \bar{N}_c] \delta(0) g_b \kappa_b G^{(1)}(t + \tau, t + \tau) \\ &\quad + \sqrt{g_b g_c} \sqrt{\kappa_b \kappa_c} \bar{N}_{bc} \delta(\tau) [G^{(1)}(t + \tau, t) + G^{(1)}(t, t + \tau)] \\ &\quad + [g_b \bar{N}_c + g_b g_c + g_c \bar{N}_b] \delta^2(0) + \langle \hat{h}_b^\dagger(t + \tau) \hat{h}_b^\dagger(t) \hat{h}_c(t) \hat{h}_c(t + \tau) \rangle, \end{aligned} \quad (32)$$

$$\begin{aligned} \Gamma_{\beta,\text{amp}}^{(2)}(t, t + \tau) &= g_b g_c \kappa_b \kappa_c G^{(2)}(t, t + \tau) + \langle \hat{h}_b^\dagger(t + \tau) \hat{h}_b^\dagger(t) \hat{h}_c(t) \hat{h}_c(t + \tau) \rangle \\ &\quad + \sqrt{g_b g_c} \sqrt{\kappa_b \kappa_c} \bar{N}_{bc} \left\{ \delta(\tau) [G^{(1)}(t + \tau, t) + G^{(1)}(t, t + \tau)] + \delta(0) [G^{(1)}(t + \tau, t + \tau) + G^{(1)}(t, t)] \right\}, \end{aligned} \quad (33)$$

where $G^{(1)}$ and $G^{(2)}$ are now the coherence functions of the cavity field \hat{a} instead of the cavity output fields, leading to the introduction of additional factors which depend on the cavity leakage rates $\kappa_{b,c}$. These expressions are directly analogous to Eqs. (26), (27), and (28).

VI. SUMMARY

We have analysed experiments for the measurement of field correlations using only field quadrature detectors and in the situation where the full record of many repetitions of the experiment are available. The combination of the quadrature measurements into complex envelopes gives direct access to anti-normally ordered field correlations. While re-ordering of the operators in the correlations and the use of phase-preserving amplifiers introduces additional noise into these measurements, we demonstrated that the noise can be accounted for and subtracted in order to reveal only the field correlations of interest. Although there are indications that the number of statistical samples scales exponentially with the order of the correlation function, the measurement of low order correlations is possible for current amplifier noise levels.

VII. ACKNOWLEDGMENTS

M.P.S. was supported by a NSERC postdoctoral fellowship. D.B. and A.W. were supported by ERC and ETHZ. A.B. was supported by NSERC, the Alfred P. Sloan Foundation and is a CIFAR Scholar.

Appendix A: Statistical error on correlation function estimates

In order to estimate the minimal number of repetitions of the experiment which must be performed to extract a given correlation function, consider the product of uncorrelated Gaussian random variables with zero mean and identical variances σ^2 . These random variables correspond to the measurements of different outputs at steady-

state after the cavity state has decayed, and the variances are given by the noise power of the measurement record (including vacuum noise). In order to illustrate the argument, we consider real valued random variables V_i first, and generalize to complex valued random variables C_i . Since these random variables are uncorrelated, it follows that $\langle V_1 V_2 \cdots V_m \rangle = 0$. However, given a finite number of statistical samples, the sample average $\overline{V_1 V_2 \cdots V_m}$ will deviate from zero due to statistical fluctuations. Signal features which are comparable with the typical size of these fluctuations cannot be reliably observed. As the typical size of these fluctuations decreases with the increasing number of repetitions, this is in principle not a fundamental problem.

In order to estimate the number of samples needed for the reliable estimation of two-point correlations, consider the product of two Gaussian random variables. The characteristic function of this product is given by

$$\phi(U) = \int_{\mathbb{R}^3} dv_1 dv_2 du p_1(v_1) p_2(v_2) \delta(v_1 v_2 - u) e^{-iUu} \quad (A1)$$

$$= \frac{1}{\sqrt{1 + U^2 \sigma^4}} \quad (A2)$$

The characteristic function of the average of R samples is given by

$$\phi_R(U) = \left[\phi \left(\frac{U}{n} \right) \right]^R. \quad (A3)$$

Given some error $\epsilon > 0$ and a number of repetitions R , the probability that the sample average $\overline{V_1 V_2}$ obeys $-\epsilon/2 < \overline{V_1 V_2} < \epsilon/2$ is given by the integral of the inverse Fourier transform of $\phi_R(U)$ over this range and simplifies to

$$\Pr(|\overline{V_1 V_2}| < \epsilon/2) = \frac{1}{2\pi} \int_{-\infty}^{+\infty} dU \phi_R(U) \frac{\sin \epsilon U/2}{U/2} \quad (A4)$$

which can be evaluated by numerically. Thus it is straightforward to calculate the number of repetitions R required to observe a feature larger than ϵ with confidence $\Pr(|\overline{V_1 V_2}| < \epsilon/2)$.

Another approach that provides a looser bound, but is more readily generalized to higher order correlations, is based on Chebyshev's inequality [45]. The variance of the product of independent random variables with zero mean is the product of the variances of each of the random variables. In the case of R samples of the product of m independent random variables V_i one finds that

$$\Pr(|\overline{V_1 V_2 \cdots V_m}| < \epsilon/2) > 1 - 4 \frac{\sigma^{2m}}{R\epsilon^2}. \quad (\text{A5})$$

Note that in order to obtain this bound no assumption was made about the form of distribution of the random variables, other than the fact that the random variables are independent. Solving for R one obtains the worst-case upper bound

$$R < \frac{4\sigma^{2m}}{\epsilon^2[1 - \Pr(|\overline{V_1 V_2 \cdots V_m}| < \epsilon/2)]}, \quad (\text{A6})$$

which makes clear the exponential relationship between the order of the correlation and the number of samples needed to have a statistical error of less than $\epsilon/2$ with some fixed probability.

In order to generalizing this to complex-valued random variables C_i – where the real and imaginary parts of C_i are independent with variance σ , and the C_i are mutually independent – simply consider the real and imaginary parts of the correlations separately. In that case, because a larger number of terms contribute to the real and imaginary parts of the correlation, the variance has a larger bound, and one finds

$$R < \frac{8m\sigma^{2m}}{\epsilon^2 \Pr(\text{error})}, \quad (\text{A7})$$

where $\Pr(\text{error})$ is the probability that the absolute value of the real or imaginary parts of $\overline{C_1 C_2 \cdots C_m}$ are greater than $\epsilon/2$.

There is no indication that taking into account the Gaussian statistics of the random variables leads to better scalings. Thus the ratio of the number of statistical samples needed to estimate $G^{(2)}$ vs. $G^{(1)}$ for some fixed noise variance and desired accuracy is at worse proportional to the noise power in the experiments. Thus the noise added by the amplifier can be the crucial element in determining the feasibility of a correlation function experiment, and it becomes even more important for higher order correlations, where the number of samples depends on the noise power raised to some larger exponent.

Appendix B: Filtering

The finite bandwidth of the detection chain can be modeled by considering the insertion of a bandpass filter in an ideal (infinite bandwidth) detection chain. In order to calculate the effect of filtering on correlation functions one can consider a general framework which describes what happens to multi-time, multi-channel correlations

when measurement signals are filtered. Assume a system with n channels where each channel is filtered individually. One can write the filtered outcome of each channel $S_{\text{fil},i}$ in terms of the input signal S_i and the filter function f_i by using the relations for linear time-invariant systems [46]

$$\begin{aligned} S_{\text{fil},i}(t_i) &= f_i(t_i) * S_i(t_i) \\ &= \int_{-\infty}^{+\infty} f_i(\tau_i) S_i(t_i - \tau_i) d\tau_i. \end{aligned} \quad (\text{B1})$$

Each channel has a separate time variable t_i to capture the case of multi-time correlations. This also clarifies with respect to which variable the convolution is done. The goal is now to express the filtered coherence function

$$G_{\text{fil}}(t_1, \dots, t_n) = S_{\text{fil},1}(t_1) S_{\text{fil},2}(t_2) \cdots S_{\text{fil},n}(t_n) \quad (\text{B2})$$

in terms of the unfiltered coherence function

$$G(t_1, \dots, t_n) = S_1(t_1) S_2(t_2) \cdots S_n(t_n). \quad (\text{B3})$$

This can be done straightforwardly by substituting Eq. (B1) into Eq. (B2).

$$G_{\text{fil}}(t_1, \dots, t_n) = \prod_{i=1}^n f_i(t_i) * S_i(t_i) \quad (\text{B4})$$

Realizing that all convolutions are related to different time variables one can rearrange this expression as

$$\begin{aligned} G_{\text{fil}}(t_1, \dots, t_n) &= \\ &f_1(t_1) * f_2(t_2) * \cdots * f_n(t_n) * G(t_1, \dots, t_n). \end{aligned} \quad (\text{B5})$$

The integral form clarifies this expression

$$\begin{aligned} G_{\text{fil}}(t_1, \dots, t_n) &= \\ &\int_{-\infty}^{+\infty} d\tau_1 \cdots \int_{-\infty}^{+\infty} d\tau_n f_1(t_1 - \tau_1) \cdots f_n(t_n - \tau_n) G(\tau_1, \dots, \tau_n). \end{aligned} \quad (\text{B6})$$

This expression can be seen as a generalized convolution with respect to more than one time variable. Introducing the global filter function

$$F(t_1, \dots, t_n) = f_1(t_1) f_2(t_2) \cdots f_n(t_n), \quad (\text{B7})$$

one can write

$$G_{\text{fil}}(t_1, \dots, t_n) = F(t_1, \dots, t_n) * G(t_1, \dots, t_n). \quad (\text{B8})$$

In frequency domain, the same fact can be expressed by using the multi-dimensional Fourier transform instead, so that one may simply write

$$G_{\text{fil}}(\omega_1, \dots, \omega_n) = G(\omega_1, \dots, \omega_n) F(\omega_1, \dots, \omega_n). \quad (\text{B9})$$

1. Two-point correlation functions

Using the spectral representation of some first-order coherence function $G(t_1, t_2)$ and the global filter function $F(t_1, t_2)$, one can write $G_{\text{fil}}(\tau)$ as

$$G_{\text{fil}}(\tau) = \int_{\mathbb{R}^3} dt d\omega_1 d\omega_2 e^{i(\omega_1 + \omega_2)t + i\omega_2\tau} F(\omega_1, \omega_2) G(\omega_1, \omega_2), \quad (\text{B10})$$

$$= \frac{1}{2\pi} \int_{-\infty}^{+\infty} d\omega e^{i\omega\tau} F(-\omega, \omega) G(-\omega, \omega). \quad (\text{B11})$$

Considering the time representation of this expression, it is clear that the correlation function will be distorted by a convolution with the effective two-point correlation function $f_{\text{eff}}(\tau) = \mathcal{F}\{F(-\omega, \omega)/2\pi\}$. Due to the linearity of the filters, one finds that Dirac δ in the noise correlations are replaced by f_{eff} , so that, for example

$$\int_{\mathcal{I}} dt \langle \hat{h}_c^\dagger(t) \hat{h}_c(t + \tau) \rangle_{\text{fil}} = \bar{N}_c f_{\text{eff}}(\tau), \quad (\text{B12})$$

where $h_c^{(\dagger)}(t)$ have been introduced in Eq. (25) and $\langle \cdot \rangle_{\text{fil}}$ indicates that the average is taken over filtered outputs. This illustrates why the values for the different second order coherence functions remain finite. Moreover, the other time-integrated two-point correlations are replaced by the convolution of the two-point correlation function with the f_{eff} .

The first-order coherence function for the periodic preparation of the cavity state $\alpha|0\rangle + \beta|1\rangle$ in the case where $\kappa t_p \ll 1$ is well approximated by

$$G^{(1)}(\tau) = \sum_j \Pi(t - jt_p, \kappa/2) \times \left[\Pi(t + \tau - jt_p, \kappa/2) \langle n(0) \rangle + \sum_{l \neq 0} \Pi(t + \tau - (j+l)t_p, \kappa/2) |\langle a(0) \rangle|^2 \right]. \quad (\text{B13})$$

where

$$\Pi(t, \kappa) = \Theta(t) \Theta(t_p - t) e^{-\kappa t}, \quad (\text{B14})$$

and Θ is the Heaviside step function. This can be interpreted as a series of time-shifted copies of $\Pi(t, \kappa/2)$, where the peak centered at $t = 0$ has a height equal to $\langle n(0) \rangle$, while the peaks centered at non-zero multiples of t_p have a height equal to $|\langle a(0) \rangle|^2$. Note that since a linear time independent filter is used, the relative heights of the peaks remain unchanged – only their shape gets distorted and scaled. This is illustrated in Fig. 6 and Fig. 7.

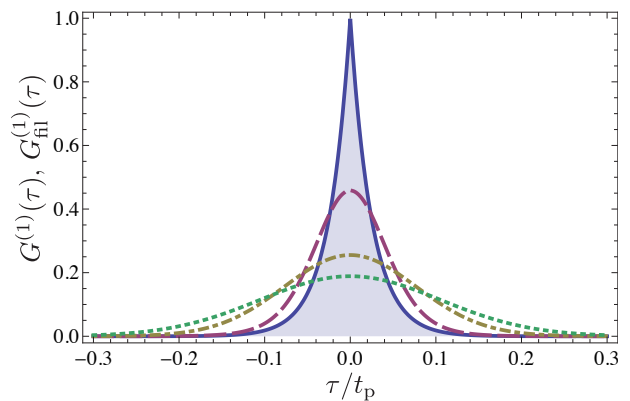

FIG. 6: Distortion of the Π pulses in $G^{(1)}(\tau)$ due to Gaussian filters of different bandwidths. The solid line is the unfiltered function, and the others are filtered bandwidth decreasing progressively: $31/t_p$ for the dashed line, $14/t_p$ for the dot-dashed line, and $10/t_p$ for the dotted line.

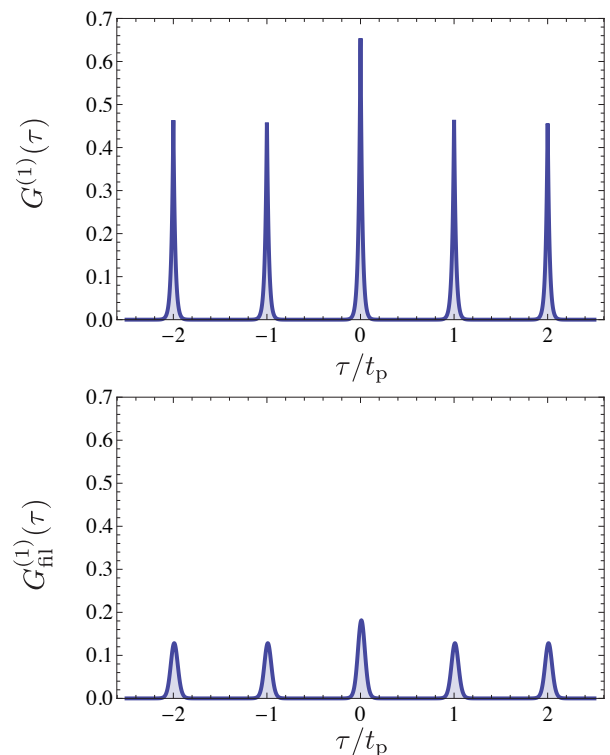

FIG. 7: The pulse train for unfiltered $G^{(1)}(\tau)$ (top) and $G_{\text{fil}}^{(1)}(\tau)$ after Gaussian filtering (bottom) under the periodic preparation of $\sqrt{1/3}|0\rangle + \sqrt{2/3}|1\rangle$. The Gaussian filter used here has a bandwidth of $31/t_p$.

2. Four-point correlation functions

Considering the second-order coherence function with filtered signals, one obtains

$$G_{\text{fil}}^{(2)}(\tau) = \int_{\mathbb{R}^5} dt d\omega_1 \dots d\omega_4 e^{i(\omega_1 + \omega_2 + \omega_3 + \omega_4)t} e^{i(\omega_2 + \omega_4)\tau} F(\omega_1, \omega_2, \omega_3, \omega_4) G^{(2)}(\omega_1, \omega_2, \omega_3, \omega_4). \quad (\text{B15})$$

The different types of correlations discussed simply determine the labeling of the variables. Applying a change of variables and integrating over time, one obtains

$$G_{\text{fil}}^{(2)}(\tau) = \frac{1}{8\pi} \int_{-\infty}^{+\infty} d\Omega_2 d\Omega_3 d\Omega_4 e^{-i\Omega_2\tau} F\left(\frac{-\Omega_2 + \Omega_4}{2}, \frac{\Omega_2 + \Omega_3}{2}, \frac{\Omega_2 - \Omega_3}{2}, \frac{-\Omega_2 - \Omega_4}{2}\right) G^{(2)}\left(\frac{-\Omega_2 + \Omega_4}{2}, \frac{\Omega_2 + \Omega_3}{2}, \frac{\Omega_2 - \Omega_3}{2}, \frac{-\Omega_2 - \Omega_4}{2}\right). \quad (\text{B16})$$

Note that this leads to significantly different behavior, in the sense that the correlation function is not simply convolved with an equivalent impulse response.

Appendix C: Commutation relations of two-sided cavity outputs

Taking both cavity mirrors to be leaky, one finds an additional boundary condition in the input-output description of the cavity [3, 31–33]

$$\hat{c}_{\text{out}} = \sqrt{\kappa_c} \hat{a} - \hat{c}_{\text{in}}, \quad (\text{C1})$$

where the $\hat{c}_{\text{in},\text{out}}$ mode are now the modes coupling to the second leaky mirror. The equation of motion Eq. (9) for \hat{a} in the rotating frame then becomes

$$\dot{\hat{a}} = -\frac{\kappa_b + \kappa_c}{2} \hat{a} + \sqrt{\kappa_b} \hat{b}_{\text{in}} + \sqrt{\kappa_c} \hat{c}_{\text{in}}. \quad (\text{C2})$$

From Eqs. (5) and (C1), one finds

$$[\hat{b}_{\text{out}}(t), \hat{c}_{\text{out}}^\dagger(t')] = \sqrt{\kappa_b \kappa_c} [\hat{a}(t), \hat{a}^\dagger(t')] - \sqrt{\kappa_b} [\hat{a}(t), \hat{c}_{\text{in}}^\dagger(t')] - \sqrt{\kappa_c} [\hat{b}_{\text{in}}(t), \hat{a}^\dagger(t')], \quad (\text{C3})$$

where the input field operators were taken to commute. Integrating the solution for the equations of motion of the modes $\hat{b}(\omega, t)$ of the left transmission line and the modes $\hat{c}(\omega, t)$ of the right transmission line, and using the definition of the input fields one obtains

$$\begin{aligned} \hat{b}_{\text{in}}(t) &= -\frac{\sqrt{\kappa_b}}{2} \hat{a}(t) + \frac{1}{\sqrt{2\pi}} \int_{-\infty}^{+\infty} d\omega \hat{b}(\omega, t), \\ \hat{c}_{\text{in}}(t) &= -\frac{\sqrt{\kappa_c}}{2} \hat{a}(t) + \frac{1}{\sqrt{2\pi}} \int_{-\infty}^{+\infty} d\omega \hat{c}(\omega, t). \end{aligned} \quad (\text{C4})$$

From causality and the boundary conditions above, one finds [33]

$$[\hat{a}(t), \hat{b}_{\text{in}}(t')] = 0, \quad [\hat{a}(t), \hat{c}_{\text{in}}(t')] = 0 \quad \text{for } t' > t \quad (\text{C5})$$

$$[\hat{a}(t), \hat{b}_{\text{out}}(t')] = 0, \quad [\hat{a}(t), \hat{c}_{\text{out}}(t')] = 0 \quad \text{for } t' < t \quad (\text{C6})$$

Combining these commutation relations with the input field definitions, one finally finds

$$\begin{aligned} [\hat{a}(t), \hat{c}_{\text{in}}^\dagger(t')] &= \sqrt{\kappa_c} u(t-t') [\hat{a}(t), \hat{a}^\dagger(t')], \\ [\hat{b}_{\text{in}}(t), \hat{a}^\dagger(t')] &= \sqrt{\kappa_b} u(t'-t) [\hat{a}(t), \hat{a}^\dagger(t')], \end{aligned} \quad (\text{C7})$$

where

$$u(t) = \begin{cases} 1 & t > 0, \\ \frac{1}{2} & t = 0, \\ 0 & t < 0, \end{cases} \quad (\text{C8})$$

and therefore

$$[\hat{b}_{\text{out}}(t), \hat{c}_{\text{out}}^\dagger(t')] = 0, \quad (\text{C9})$$

as claimed.

-
- [1] D. Bozyigit, C. Lang, L. Steffen, J. M. Fink, M. Baur, R. Bianchetti, P. J. Leek, S. Filipp, M. P. da Silva, A. Blais, et al. (2010), arXiv:1002.3738.
- [2] L. Mandel and E. Wolf, *Optical coherence and quantum optics* (Cambridge University Press, 2008), 1st ed.
- [3] D. Walls and G. J. Milburn, *Quantum Optics* (Springer, 2008), 2nd ed.
- [4] R. J. Glauber, Phys. Rev. Lett. **10**, 84 (1963).
- [5] R. J. Glauber, Phys. Rev. **130**, 2529 (1963).
- [6] L. Mandel and E. Wolf, Rev. Mod. Phys. **37**, 231 (1965).
- [7] H. Paul, Rev. Mod. Phys. **54**, 1061 (1982).
- [8] L. Davidovich, Rev. Mod. Phys. **68**, 127 (1996).
- [9] C. Kurtsiefer, S. Mayer, P. Zarda, and H. Weinfurter, Phys. Rev. Lett. **85**, 290 (2000).
- [10] Z. Yuan, B. E. Kardynal, R. M. Stevenson, A. J. Shields, C. J. Lobo, K. Cooper, N. S. Beattie, D. A. Ritchie, and M. Pepper, Science **295**, 102 (2002).
- [11] M. Keller, B. Lange, K. Hayasaka, W. Lange, and H. Walther, Nature **431**, 1075 (2004).
- [12] K. M. Birnbaum, A. Boca, R. Miller, A. D. Boozer, T. E. Northup, and H. J. Kimble, Nature **436**, 87 (2005).
- [13] M. Hijlkema, B. Weber, H. P. Specht, S. C. Webster, A. Kuhn, and G. Rempe, Nat. Phys. **3**, 253 (2007).
- [14] A. Wallraff, D. I. Schuster, A. Blais, L. Frunzio, R.-S. Huang, J. Majer, S. Kumar, S. M. Girvin, and R. J. Schoelkopf, Nature **431**, 162 (2004).

- [15] D. I. Schuster, A. A. Houck, J. A. Schreier, A. Wallraff, J. M. Gambetta, A. Blais, L. Frunzio, J. Majer, B. Johnson, M. H. Devoret, et al., *Nature* **445**, 515 (2007).
- [16] A. Wallraff, D. I. Schuster, A. Blais, J. M. Gambetta, J. Schreier, L. Frunzio, M. H. Devoret, S. M. Girvin, and R. J. Schoelkopf, *Phys. Rev. Lett.* **99**, 050501 (2007).
- [17] A. A. Houck, D. I. Schuster, J. M. Gambetta, J. A. Schreier, B. R. Johnson, J. M. Chow, L. Frunzio, J. Majer, M. H. Devoret, S. M. Girvin, et al., *Nature* **449**, 328 (2007), ISSN 0028-0836.
- [18] O. Astafiev, K. Inomata, A. O. Niskanen, T. Yamamoto, Y. A. Pashkin, Y. Nakamura, and J. S. Tsai, *Nature* **449**, 588 (2007).
- [19] M. Hofheinz, E. M. Weig, M. Ansmann, R. C. Bialczak, E. Lucero, M. Neeley, A. D. O'Connell, H. Wang, J. M. Martinis, and A. N. Cleland, *Nature* **454**, 310 (2008).
- [20] J. M. Fink, M. Göppl, M. Baur, R. Bianchetti, P. J. Leek, A. Blais, and A. Wallraff, *Nature* **454**, 315 (2008).
- [21] C. A. Regal, J. D. Teufel, and K. W. Lehnert, *Nat. Phys.* **4**, 555 (2008).
- [22] M. A. Castellanos-Beltran, K. D. Irwin, G. C. Hilton, L. R. Vale, and K. W. Lehnert, *Nat. Phys.* **4**, 429 (2008).
- [23] M. Hofheinz, H. Wang, M. Ansmann, R. C. Bialczak, E. Lucero, M. Neeley, A. D. O'Connell, D. Sank, J. Wenner, J. M. Martinis, et al., *Nature* **459**, 546 (2009).
- [24] O. Astafiev, A. M. Zagoskin, A. A. Abdumalikov, Y. A. Pashkin, T. Yamamoto, K. Inomata, Y. Nakamura, and J. S. Tsai, *Science* **327**, 840 (2010).
- [25] M. Mariantoni, M. J. Storcz, F. K. Wilhelm, W. D. Oliver, A. Emmert, A. Marx, R. Gross, H. Christ, and E. Solano (2005), arXiv:cond-mat/0509737.
- [26] E. P. Menzel, F. Deppe, M. Mariantoni, M. A. A. Caballero, A. Baust, T. Niemczyk, E. Hoffmann, A. Marx, E. Solano, and R. Gross (2010), arXiv:1001.3669.
- [27] M. Mariantoni, E. P. Menzel, F. Deppe, M. A. A. Caballero, A. Baust, T. Niemczyk, E. Hoffmann, E. Solano, A. Marx, and R. Gross (2010), arXiv:1003.3194.
- [28] J. M. Raimond, M. Brune, and S. Haroche, *Rev. Mod. Phys.* **73**, 565 (2001).
- [29] H. Mabuchi and A. C. Doherty, *Science* **298**, 1372 (2002).
- [30] A. Blais, R.-S. Huang, A. Wallraff, S. M. Girvin, and R. J. Schoelkopf, *Phys. Rev. A* **69**, 062320 (2004).
- [31] M. J. Collett and C. W. Gardiner, *Phys. Rev. A* **30**, 1386 (1984).
- [32] C. W. Gardiner and M. J. Collett, *Phys. Rev. A* **31**, 3761 (1985).
- [33] C. Gardiner and P. Zoller, *Quantum Noise: A Handbook of Markovian and Non-Markovian Quantum Stochastic Methods with Applications to Quantum Optics* (Springer, 2004), 3rd ed.
- [34] H.-A. Bachor and T. C. Ralph, *A guide to experiments in quantum optics* (Wiley-VCH, 2004), 2nd ed.
- [35] J. Gabelli, L.-H. Reydellet, G. Fève, J.-M. Berroir, B. Plaçaïs, P. Roche, and D. C. Glatli, *Phys. Rev. Lett.* **93**, 056801 (2004).
- [36] D. M. Pozar, *Microwave Engineering* (Wiley, 2004), 3rd ed.
- [37] A. Lupaşcu, E. F. C. Driessen, L. Roschier, C. J. P. M. Harmans, and J. E. Mooij, *Phys. Rev. Lett.* **96**, 127003 (2006).
- [38] J. D. Teufel, T. Donner, M. A. Castellanos-Beltran, J. W. Harlow, and K. W. Lehnert, *Nature Nanotech.* **4**, 820 (2009).
- [39] N. B. Grosse, T. Symul, M. Stobinska, T. C. Ralph, and P. K. Lam, *Phys. Rev. Lett.* **98**, 153603 (2007).
- [40] W. P. Schleich, *Quantum optics in phase space* (Wiley-VCH, 2001), 1st ed.
- [41] K. Husimi, *Proc. Phys. Math. Soc. Jpn.* **22**, 264 (1940).
- [42] Y. Kano, *J. Math. Phys.* **6**, 1913 (1965).
- [43] A. A. Clerk, M. H. Devoret, S. M. Girvin, F. Marquardt, and R. J. Schoelkopf, *Rev. Mod. Phys.* **82**, 1155 (2010).
- [44] C. M. Caves, *Phys. Rev. D* **26**, 1817 (1982).
- [45] J. S. Rosenthal, *A first look at rigorous probability theory* (World Scientific, 2009), 2nd ed.
- [46] J. G. Proakis and D. K. Manolakis, *Digital Signal Processing* (Prentice Hall, 2006).